

BIRKIN
S3

OWNERS MANUAL

CONTENTS

Registration Form	3
Introduction	4
Know Your Vehicle	5
Regular Maintenance	16
Service Data	20
Service Record	22

BIRKIN OWNERS REGISTRATION

Questions marked with (*) are optional and are general information for our records.
Either fax (+27 31 7091287) or email (info@birkin.co.za) us your details

Name:-

*Age:-

Postal Address:-

Country:-

Contact Telephone Number:-

Email Address:-

*Profession:-

Vehicle Model:-

V.I.N. / Chassis Number:-

Engine Number:-

Supplying Dealer:-

Date of Delivery:-

Registration Number:-

I wish to be kept updated on new developments, promotions, new accessories:-

Yes

No

INTRODUCTION

In producing this manual, the object has been to confine the contents to information essential to the proper running and operation of the vehicle.

Nevertheless, the operator will find all the guidance necessary to maintain the vehicle in first-class condition and to ensure trouble free service. Every vehicle leaving the factory is capable of giving absolute satisfaction if the maintenance instructions detailed in the following pages are carefully carried out.

Remember that an approved Distributor/Dealer is better equipped to provide routine repair and service than most, he is at your service and should be consulted if you encounter trouble. When emergency work has been undertaken by someone other than a competent workshop, the vehicle should be submitted to an approved Distributor/Dealer for inspection.

All warranty work must be carried out by an approved Distributor/Dealer.

Official Dealer must perform scheduled services to preserve warranty.



KNOW YOUR VEHICLE

It is important to become familiar with your vehicles instruments, controls and switches before driving, so that using them becomes automatic and instinctive.

Identification - Factory Built Vehicles

VIN number: 17 digit identification number on a plate which is welded to the top left hand diagonal brace in the engine bay.

Engine number: stamped onto the left side of the engine block at the rear next to the bellhousing.

FUSE BOX

Situated in the Engine Bay

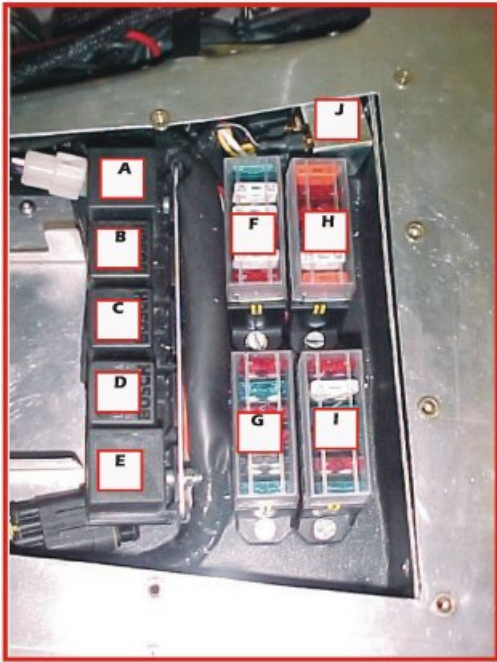

- A** HAZARD RELAY
- B** IGNITION RELAY
- C** LIGHTS RELAY
- D** HEATED W/SCREEN RELAY
- E** INDICATOR RELAY

Fuse Box#1

LOW BEAM	15 AMP
HI BEAM	25 AMP
RAD FAN	25 AMP
F BRAKE	10 AMP
HEAD	25 AMP
HAZARD	10 AMP

Fuse Box#2

PARK	10 AMP
E.C.U.	15 AMP
RESERVOIR	10 AMP
G REVERSE	10 AMP
FUEL PUMP	15 AMP
REAR FOG	15 AMP

Fuse Box#4

J DIP RELAY	
MAIN	40 AMP
HORN	10 AMP
SEAT BELT	7.5 AMP
H HANDBRAKE	7.5 AMP
SPARE	25 AMP
SPARE	40 AMP

Fuse Box#3

INDICATOR	10 AMP
WASHER	25 AMP
W/SCREEN	15 AMP
I HEATER	15 AMP
GAUGES	10 AMP
WIPER	15 AMP

DASHBOARD LAYOUT for Right Hand Vehicle

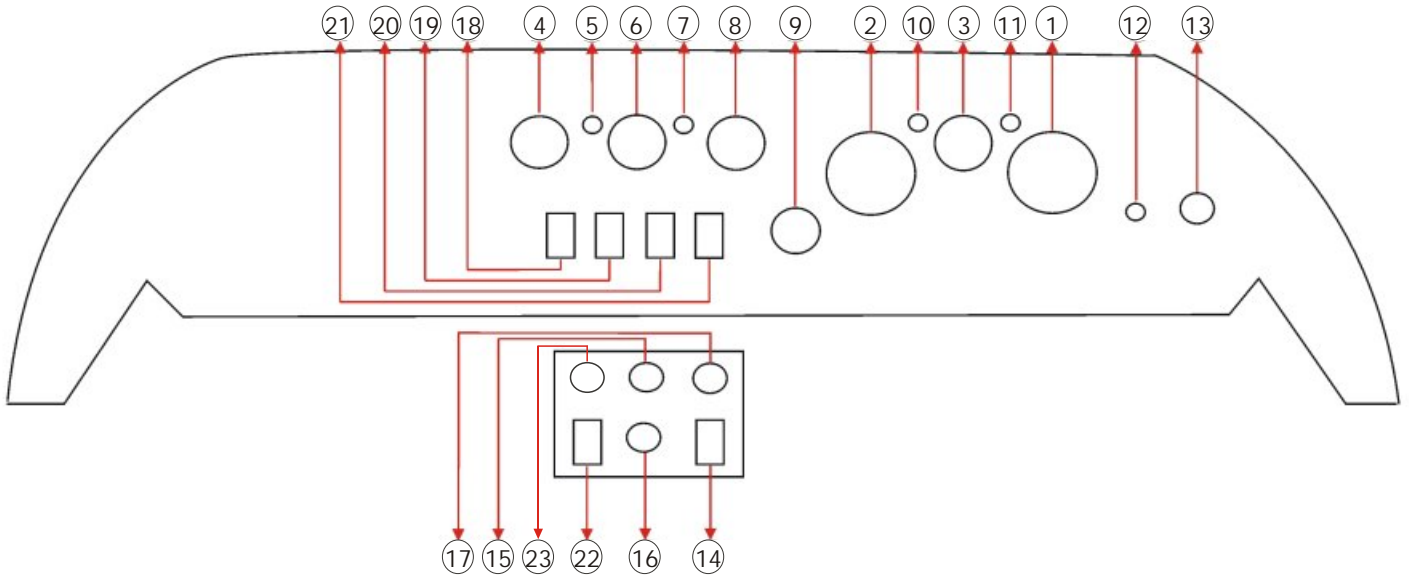

KEY

- | | | |
|---------------------------|---|-------------------------------------|
| 1 Speedometer | 9 Dip switch | 16 Windscreen washer switch |
| 2 Rev counter/Tachometer | 10 Indicator light | 17 Handbrake warning light |
| 3 Oil pressure gauge | 11 Brake fluid warning light | 18 Demister switch |
| 4 Ammeter | 12 Indicator switch | 19 Emergency lights switch |
| 5 High beam warning light | 13 Hooter switch | 20 Windscreen wipers switch |
| 6 Water temperature gauge | 14 Test switch - Brake Fluid warning circuit (Optional) | 21 Lights switch |
| 7 Ignition light | 15 Heater fan switch | 22 Rear fog light switch (Optional) |
| 8 Fuel gauge | | 23 Seat belt warning light |

DASHBOARD LAYOUT for Left Hand Vehicle

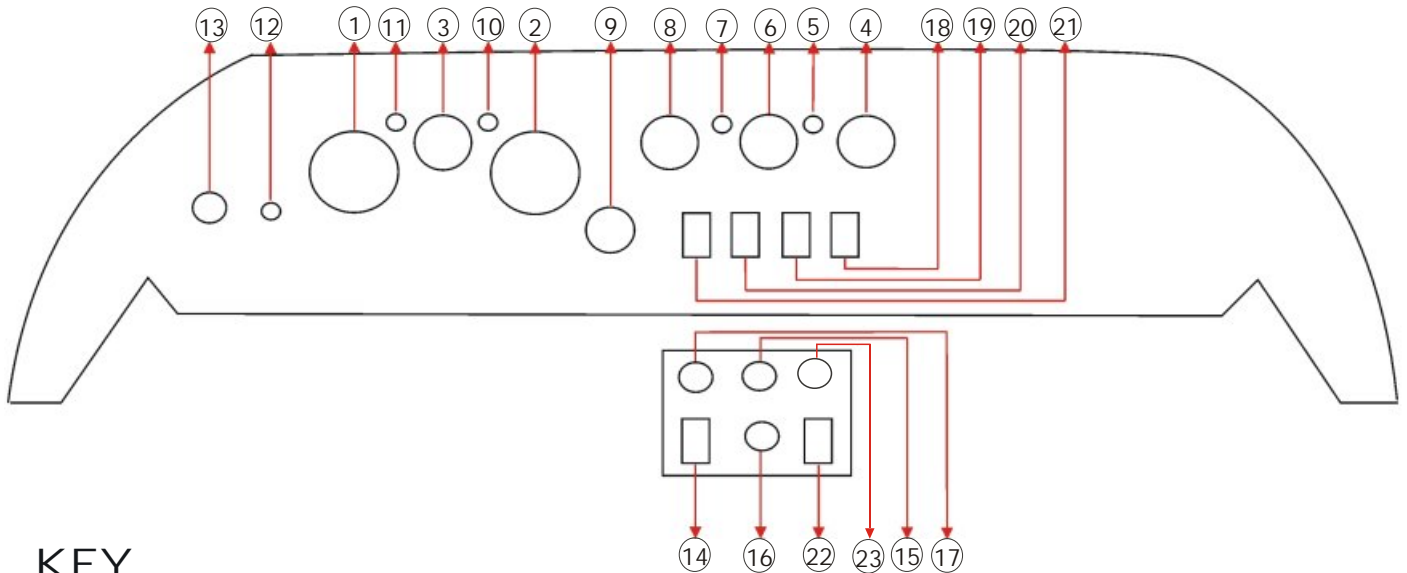

KEY

- | | | |
|---------------------------|---|-------------------------------------|
| 1 Speedometer | 9 Dip switch | 16 Windscreen washer switch |
| 2 Rev counter/Tachometer | 10 Indicator light | 17 Handbrake warning light |
| 3 Oil pressure gauge | 11 Brake fluid warning light | 18 Demister switch |
| 4 Ammeter | 12 Indicator switch | 19 Emergency lights switch |
| 5 High beam warning light | 13 Hooter switch | 20 Windscreen wipers switch |
| 6 Water temperature gauge | 14 Test switch - Brake Fluid warning circuit (Optional) | 21 Lights switch |
| 7 Ignition light | 15 Heater fan switch | 22 Rear fog light switch (Optional) |
| 8 Fuel gauge | | 23 Seat belt warning light |

PEDAL BOX ADJUSTMENT

The pedal box can be moved forward or backwards by positioning the pedal box locating bolts in one of the four positions indicated below.

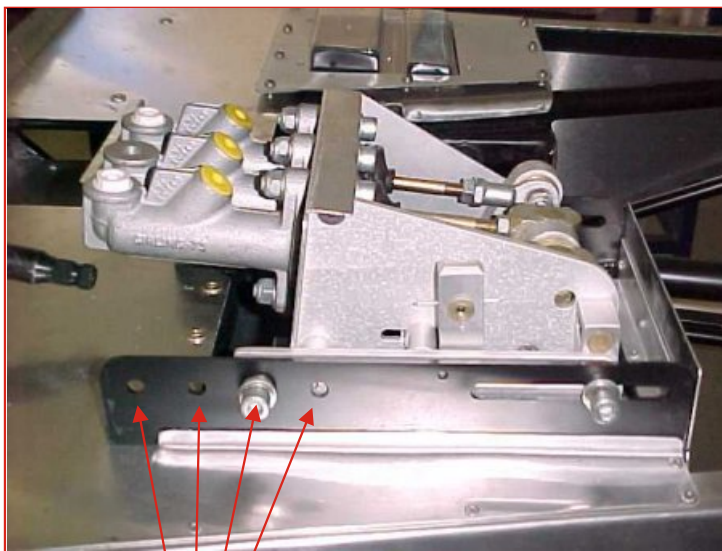

Pedal box adjustment fasteners

CLUTCH, BRAKE AND ACCELERATOR PEDAL ADJUSTMENT

The pedal pads may be adjusted vertically and laterally by using alternative mounting positions on the clutch, brake and acceleratory pedals as shown below.



1. Default (factory set) position of the pedals on the pedal box as shown from back of pedals.



2. View showing clutch pedal (right) raised vertically upwards.



3. View showing lateral adjustment of clutch pedal (right pedal) positioned on left side of lever arm.

BRAKE BIAS ADJUSTMENT

It is possible to adjust the braking bias between the front and rear by adjusting the Bias Bar on the pedal box. Instructions follow on next page.

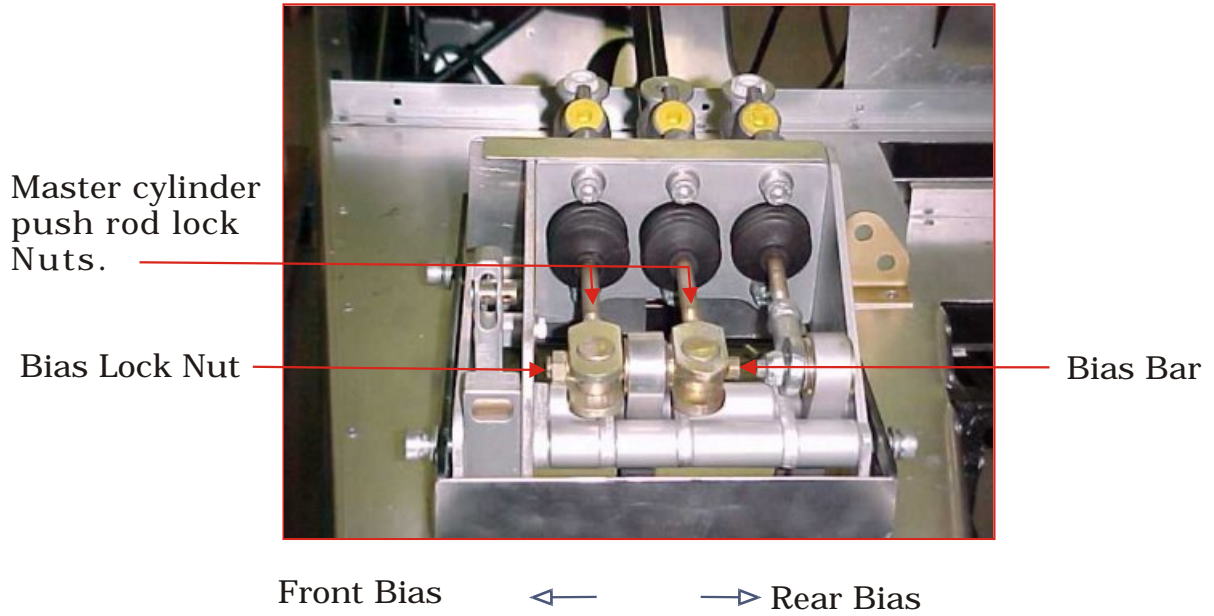

Instructions for setting adjustment on Bias Bar:

1. Loosen the master cylinder push rod lock nuts (point #1) and adjust the push rod lengths until they are equal, with approximately 0,5mm free-play.
2. Loosen the bias lock nut (point #2) with a 13 mm spanner.
3. Using a screwdriver (point #3), rotate the bias bar (point #4) in a clockwise direction to increase braking to rear or anticlockwise to increase to the front.
4. Once set, nip up lock nut before replacing cover.

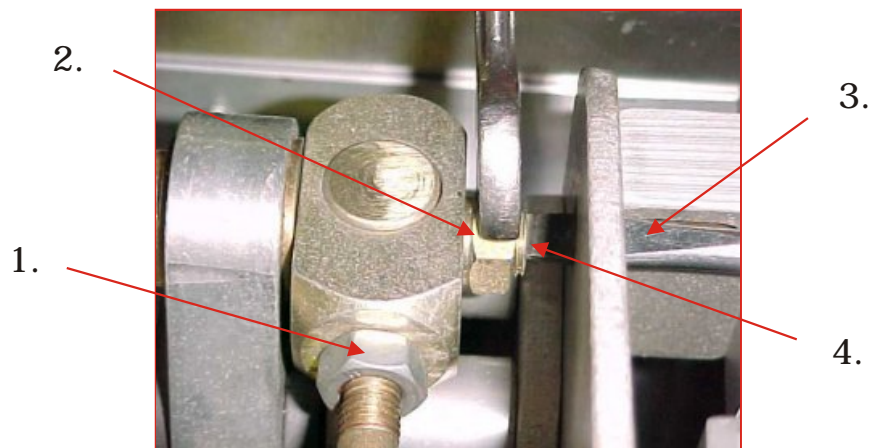

HANDBRAKE ADJUSTMENT

The handbrake tension must be set correctly as described below.

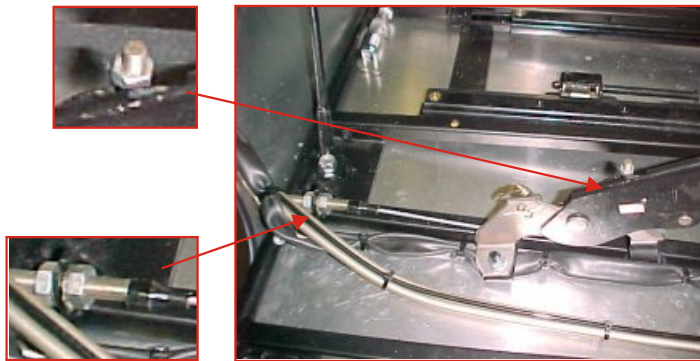

By adjusting the nuts on the handbrake (as indicated), the tension to the handbrake can be adjusted accordingly. It is recommended that the tension be set so that the handbrake begins to take after 2 'clicks' and that it is fully engaged after 4 to 5 'clicks'.

For previous models that used Honda calipers, the handbrake tension on each Caliper (ie the balance) may be set independently by adjusting the nuts.

- Firstly, adjust the tension on one Caliper until the brake disk does not rotate at all.
- Now, reduce the tension gradually until the disk rotates freely while keeping count of the number of turns of the nut.
- Repeat for the opposite Caliper. The number of turns for both should be the same.

The calipers are self adjusting in the newer models.

ADJUSTING THE RIDE HEIGHT

The factory ride height settings are as such:

- At the rear, the ring retainer nut is set 20mm (15 threads) up.

To adjust the ride height of either the rear or the front suspension:

1. Loosen the grub screw on the ring retainer nut using the appropriate allen key.
2. Adjust the ring retainer nut up or down as required.
3. Lock the grub screw that was loosened in step 1.

Relative diagrams appear on the next page.

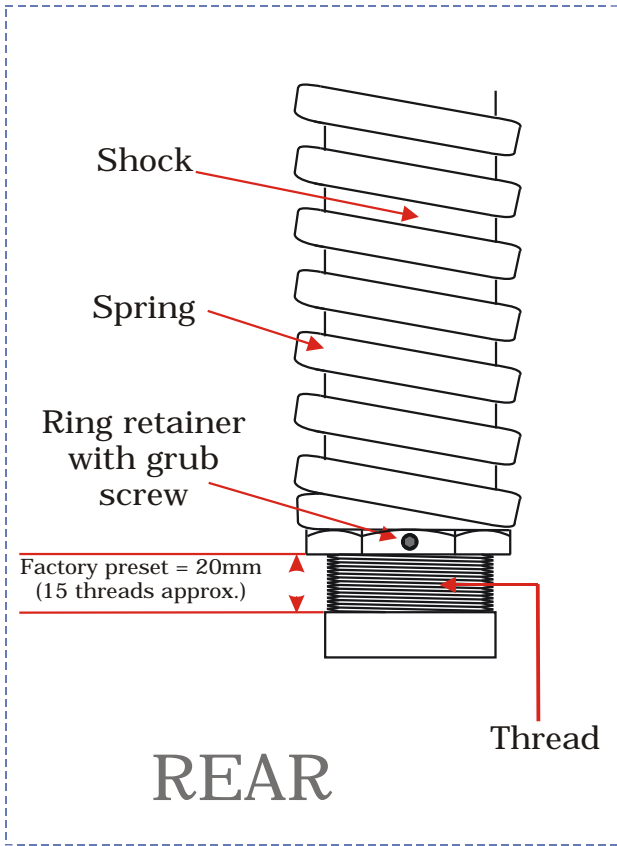

REGULAR MAINTENANCE

Before performing any maintenance on your vehicle, ensure the engine is not running and the handbrake is engaged, unless otherwise instructed in the text that follows. Be sure to keep tools, hands and any parts away from any moving parts.

Oil Level: Important! First park the car on level ground and then wait a few minutes before checking the dipstick with a clean rag. The two marks on the dipstick indicate minimum and maximum oil levels, the difference between the marks being 500ml. If your vehicle is fitted with a dry sump system, the nose cone must be removed to allow the level indicator to be visible. Perform a visually check on the oil pump drive belt to confirm it has not become worn and then start the engine. Through the filler cap you will notice a baffle plate, the oil level must be just below this while the engine is running. Should the oil need topping up, switch off the engine first before refilling. It is then important to warm up the engine before driving as the viscosity of cold oil will put strain on the oil pump drive belt causing unnecessary wear.

Water Level: Every 20,000km the coolant system should be flushed and replaced with a recommended anti-corrosion inhibitor.
DO NOT REMOVE THE FILLER NECK CAP WHILST THE ENGINE IS HOT.
The pressure and temperature of water and/or engine coolant from a hot engine is extremely high and capable of causing severe injury or burns should these instructions be ignored. Should an emergency occur where the filler neck cap has to be removed while the engine is hot, protect yourself by muffling the cap with a thick rag and rotate it in the opening direction very slowly. This allows a gradual release of any harmful pressure and potentially scolding steam before the removal of the cap.

Brake Fluid:

BRAKE FLUID IS A HIGHLY CORROSIVE AND POTENTIALLY DANGEROUS SUBSTANCE.

It should therefore, be used with the utmost care and stored safely away from other substances and out of harms reach.

The minimum and maximum marks can be found on the side of the reservoir. Should it be necessary to top up any levels, take care not to overfill the container and only use recommended brake fluid which has not been exposed to the atmosphere. Should any brake fluid spill over or come in contact with anything other than the inside of the reservoir, wash down the affected area immediately with cold water.

It is advisable to protect your skin and eyes when working with Brake Fluid. In the event of it coming in contact with any part of the human body, follow the medical instructions provided by the brake fluid manufacturer or contact a medical practitioner immediately.

Battery:

The supplied battery is a sealed and maintenance free.

Fan Belt:

Check movement of the belt between the water pump pulley and the alternator pulley. The belt should have a free play of 10mm with normal wrist movement.

Air Cleaner:

The factory fitted air cleaners should never require replacement. A filter cleaning solution is available through after-market engine accessory shops.

- Tyres:* Tyre pressures should be checked when the tyres are cold. The recommended pressures are 180Kpa all round, and be sure to check the spare. Regular tyre maintenance and wheel alignment will ensure a longer tyre life and an economic fuel consumption.
- Bodywork:* The aluminium bodywork is best kept clean by using a metal polish such as 'Brasso'. Fine scratches can be removed by using a rubbing compound. The paintwork should be washed frequently using lukewarm water, and dried off using a chamois cloth. A good wax on the paint is recommended once a month. The use of high pressure water hoses or steam cleaners is not recommended. Use of such can cause damage to the bodywork and or autoelectrical failure..
- Upholstery:* Keep the upholstery clean by using a suitable after-market product such as 'Armourall'. This is recommended not only for upholstery, but for rubber components aswell.
- Weather Trim:*
1. Wet trim must be left on the car to dry with all the press studs fastened. Do not pack trim away when wet.
 2. The hood must be fitted starting from the windscreen first. The reverse applies when taking the hood off. (start from the rear)
 3. To fit the tonneau cover, start by connecting the zip to the boot cover first. Next, fasten the front press studs and working your way down the sides towards the rear.
 4. When using weather trim, always ensure all press studs are securely fastened.

Jacking Points

Jacks must be placed under the steel members of the chassis in the positions as indicated by red crosses below.

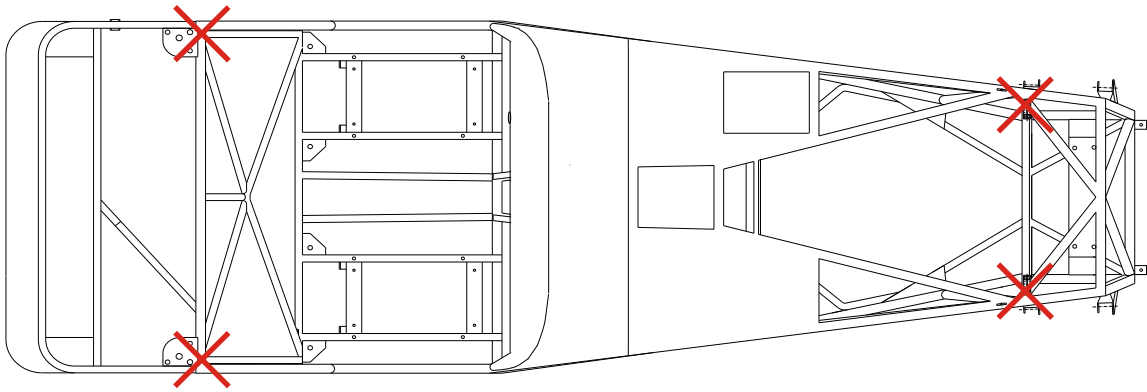

SERVICE DATA

Service Intervals

The service intervals are applicable to the vehicles fitted with Ford Zetec engines.

PRE-DELIVERY SERVICE	2500km MINOR SERVICE	15 000km MIDWAY SERVICE	30 000km MAJOR SERVICE
-------------------------	----------------------------	-------------------------------	------------------------------

An optional 5000 km service is recommended for vehicles which travel less than 1000 km every year.

Scheduled Service Tasks

Weekly Checks

- Check the oil level and top up if necessary
- Check the brake fluid level, and top up if necessary
If repeated topping up is required, check the system for leaks or damage at the earliest possible opportunity
- Check the windscreen washer fluid level, and top up if necessary
- Check the tyre pressures, including the spare
- Visually check the tyres for excessive tread wear, or damage
- Check the operation of all (exterior and interior) lights and the horn, wipers and windscreen washer system
Renew any blown bulbs and clean the lenses of all exterior lights

Monthly Checks

- Check the coolant level and top up if necessary
- Check the battery electrolyte level, where applicable
- Check the operation of the handbrake
- Check the aim of the windscreen washer jets and correct if necessary
- Visually check all reservoirs, hoses and pipes for leakage
- Check the condition of the wiper blades, renewing them if worn or no longer effective - note that the manufacturer recommends renewing the blades as a safety precaution, irrespective of their apparent condition, at least once a year

First 1000 km inspection

- Renew oil and oil filter
- Conduct full vehicle check in accordance with 10 000 km service

Every 3 years (regardless of mileage)

- Renew the brake fluid

Every 10 000 km or 12 months, whichever occurs first

- Check the electrical system
- Check the battery
- Check the seat belts
- Check the auxiliary drivebelt
- Check for fluid leaks and hose condition
- Check the condition of all wiring
- Renew the coolant
- Change the engine oil and filter
- Check the manual transmission oil level
- Check the adjustment of the clutch pedal
- Check the steering, suspension and wheels
- Check the CV joints and driveshaft gaiters
- Check the exhaust system
- Check the underbody, and all fuel/brake lines
- Check the brake system
- Check and lubricate the doors and bonnet
- Check the security of all roadwheel nuts
- Road test

Every 30 000 km or 3 years, whichever occurs first

- Renew the air filter element
Note that this task must be carried out at more frequent intervals if the vehicle is used in dusty or polluted conditions
- Check the Positive Crankcase Ventilation system, and clean the filter
- Renew the spark plugs

Every 60 000 km

- Renew the timing belt
- Renew the fuel filter

SERVICE RECORD

DEALER
DEALER STAMP
Date:
Mileage:

DEALER
DEALER STAMP
Date:
Mileage:

DEALER
DEALER STAMP
Date:
Mileage:

DEALER
DEALER STAMP
Date:
Mileage:

DEALER
DEALER STAMP
Date:
Mileage:

DEALER
DEALER STAMP
Date:
Mileage:

DEALER
DEALER STAMP
Date:
Mileage:

DEALER
DEALER STAMP
Date:
Mileage:

SERVICE RECORD

DEALER
DEALER STAMP
Date:
Mileage:

DEALER
DEALER STAMP
Date:
Mileage:

DEALER
DEALER STAMP
Date:
Mileage:

DEALER
DEALER STAMP
Date:
Mileage:

DEALER
DEALER STAMP
Date:
Mileage:

DEALER
DEALER STAMP
Date:
Mileage:

DEALER
DEALER STAMP
Date:
Mileage:

DEALER
DEALER STAMP
Date:
Mileage: