

# GROUP SIX

1st Edition

## LIGHTS

### Contents of this group:-

6:1	K3601121AA	TAIL LIGHTS
6:2	K3601122AB	HEAD LIGHTS
6:3	K3601123AB	WIRING
6:4	K3601125AB	WIRING AND SWITCHES
6:5	K3601124AA	INDICATOR PILOT LIGHTS

### Tools required for assembly of this group: -

8mm Spanner	1	22mm Hole saw	1	Masking tape	1
10mm Spanner	1	Screwdrivers		Spirit level	1
3.5mm Drill Bit	1	Side cutters	1	Measuring tape	1
5.2mm Drill Bit	1	Craftsman knife	1	Plumbline	1
Drill Machine	1				



K3601122AB HEAD LIGHTS



K3601121AA TAIL LIGHTS



K3601124AA INDICATOR PILOT LIGHTS

## 6:1 TAIL LIGHT - K3601121AA

Components in this assembly		Qty	Part Number
i	Reflector	2	B5451139AA
ii	Tail light assembly	2	M3501014AA

### Tail light fitting Procedure

1. Using a 5.2mm drill bit, drill holes on the tail light mounting section of the right hand mudguard using below illustration as a guide.

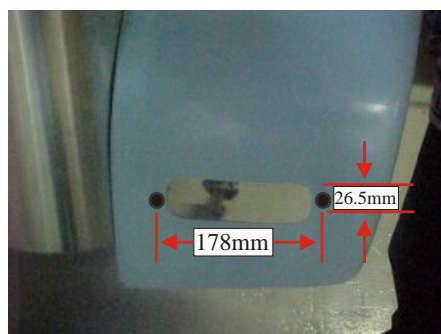

2. Remove nuts and washers from tail light assembly (ii) mounting bolts.

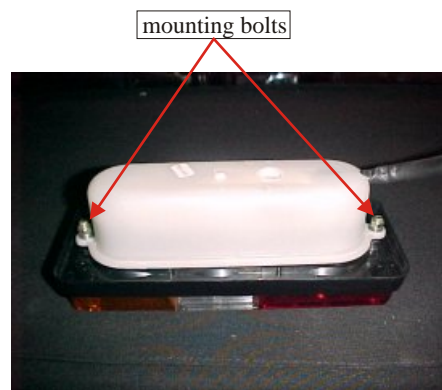

3. Slide tail light into the cut-out on the mudguard with the mounting bolts fitting into the holes drilled in point #1. Indicator lens should be to the outside of the mudguard.



4. Re-fit the nuts and washers removed in point #2.



Nuts and washers



5. Using the spirit level to ensure that the tail light is horizontal as illustrated below. A slight modification of the holes drilled in point #1 may be required if the absolute horizontal position of the tail light cannot be obtained. Torque mounting nuts to 5Nm.



It is recommended that the inside of the fender wheel arch and cladding is coated with a good quality rubberised undercarriage coating to absorb any stones or road debris from damaging the fender or cladding.

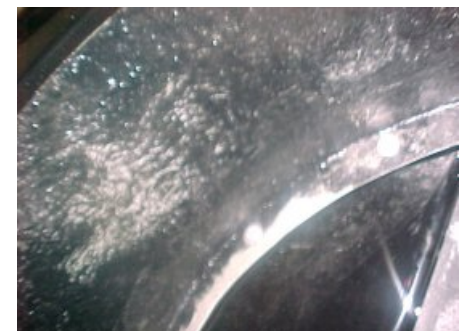

## Tail light fitting Procedure continue

---

6. Feed the tail light harness through the grommet mounted on the chassis. Using the 4 pin plug supplied in Group 6 Wiring kit (K3601123AB), connect the harness of the taillight to the main harness. You need to ensure that the colours of the wires correspond on either side of the 4 pin plug.



---

7. Repeat steps 1 - 6 for the Left hand side of the vehicle.

## 6:2 HEAD LIGHT - K3601122AB

Components in this assembly		Qty	Part Number
i	Nut M6 Nyloc	4	B5358078AA
ii	Washer 6mm flat	8	B5358090AA
iii	Setscrew M6 x 30	4	B5358097AA
iv	Headlight kit L/H	1	M3501030AA
v	Headlight kit R/H	1	M3501031AA



**Headlight mounting brackets on the chassis.**

Headlight mounting brackets

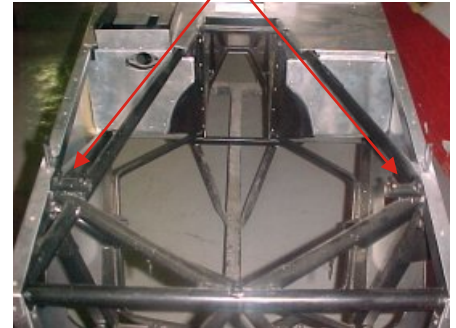

### Head light Procedure

1. Slide the tube of the right hand headlamp mounting bracket into the split tube welded to the frame on the right hand side until the end of the tube is flush to the end of the split tube.

2. Using two M6x30 setscrews, four M6 flat washers and two M6 Nyloc nuts, insert into the two clamping tubes welded at the top of the split tube. The outer mounting setscrew should also be used as a ground connecting point for the main loom. This setscrew should be fitted with two 6mm ring terminals as illustrated.



M6 Washers

6mm Ring terminal

3. Using a straight edge, ensure that the head lamp mounting bracket is parallel to the top frame member. Torque setscrews to 11Nm.

4. Connect the headlight harness to the mating connector from the main harness ensuring the colours of the wires correspond.

5. Repeat steps 1 -4 with the clamping tube on the left hand side.



Components in this assembly		Qty	Part Number
i	Washer 3mm rivet	2	B5358093AA
ii	Rivet AS 3212	2	B5358095AA
iii	Capscrew M5 x 10	2	B5358252AA
iv	Nut M5 Nyloc	2	B5358089AA
v	Washer 5mm x 10 flat	4	B5358094AA
vi	Fuse link	1	B5451128AA
vii	Fuse 40AMP	1	B5451129AA
viii	Sleeving 4mm PVC	1	B5451315AA
ix	Sleeving 6mm PVC	1	B5451317AA
x	Cable tie	10	B5451366AA
xi	Terminal female 6.3	9	B5451403AA
xii	Terminal male 6.3	1	B5451424AA
xiii	Plug male 4 pin	2	B5451495AA
xiv	Plug male 1 pin	1	B5451497AA
xv	Plug female 1 pin	1	B5451500AA
xvi	Audible warning device	1	B5451587AA
xvii	Plug male 8 pin	3	B5451735AA
xviii	Terminals 15 pin	3	B5451791AA
xix	ECU Mounting bracket	1	M3201131AA
xx	Indicator wiring	2	M3501019AA
xxi	Brake fluid warning light loom	1	M3501039AA



**Consult the wiring diagram (found on the last page of this group) when fitting components in this procedure.**

**8 Pin male plug fitting procedure**

**1. Fit the male plug 8 pin into the female plug 8 pin (fitted in Group 5) with wire colours matching on either side of the 8 pin plug union.**

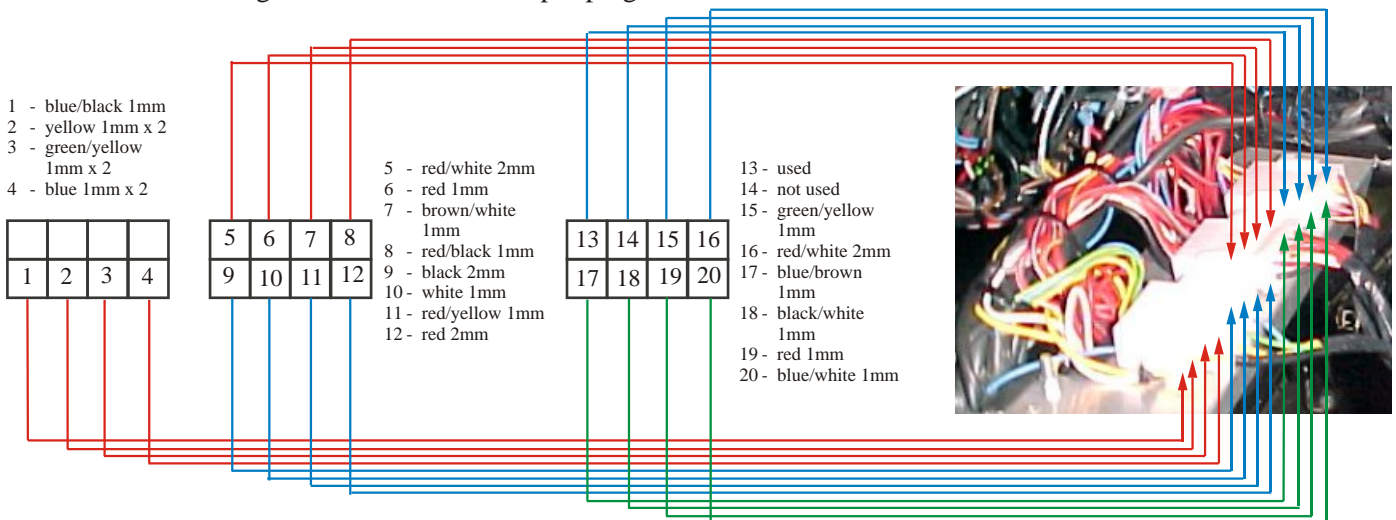

## 8 Pin male plug fitting procedure continue

2. The male terminals should fit into the female plugs.

3. The female terminals should fit into the male plugs.



**This procedure must be completed prior to the fitting of the scuttle.**

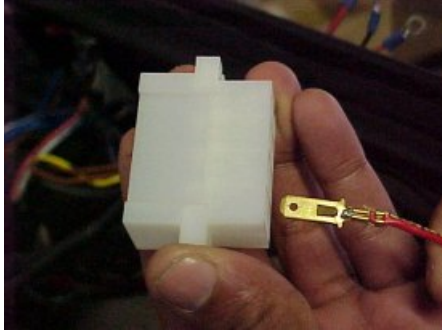

## Indicator wiring fitting procedure

1. Connect indicator wiring to main loom. The connection point is at the headlamp mounting bracket to chassis point. Use a M6 bolt as an earth connection.

2. Connect the 1 pin plug on the indicator loom to the 1 pin plug on the main loom, depending on the side, it will either be a yellow (right hand) or yellow with a green stripe (left hand) wire.

3. Run loom with front brake hose and attach with cable ties. Insert into cycle fender bracket through M6 hole as per illustration.

Connection point  
Earth

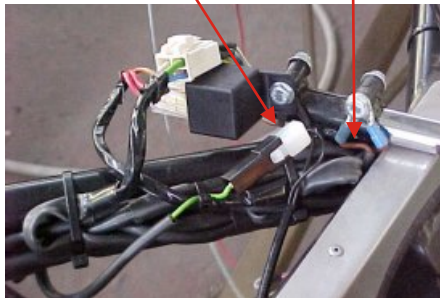

yellow/green wire  
1 Pin plug

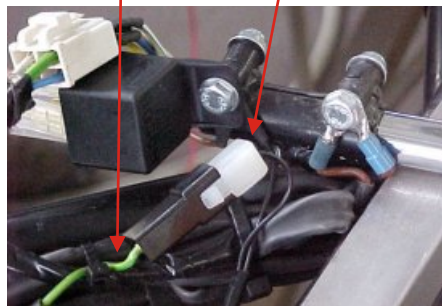

cable ties  
M6 hole



4. The loom will exit at the top of the bracket, near the mounting point of the cycle fender to the bracket.

5. Remove the mounting bracket from the fender. Remove a portion of the rubber attached to the bracket as illustrated below.

6. Attach 'P' clip to indicator wiring loom.

loom exiting top of bracket

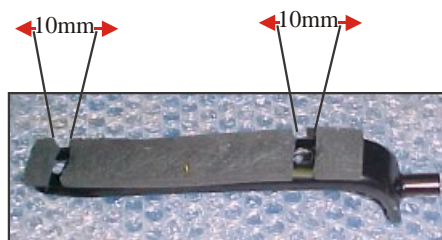

'P' clips



## Indicator wiring fitting procedure continue

---

7. Refit the bracket to the cycle fender. The 'P' clips are located between the fender and bracket.

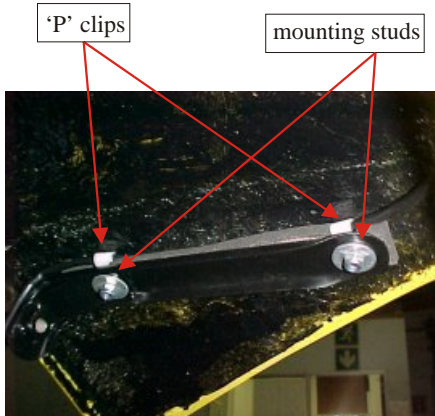

## Audible Warning Device (A.W.D) fitting procedure

---



**This is to be fitted after switches and gauges have been fitted to the dashboard.**

Black wire should be earth. Red wire should be connected to the middle pin on the indicator switch. Cable tie A.W.D to loom



## Brake fluid warning light loom fitting procedure

---



**To be fitted after the scuttle and reservoir mounting bracket and reservoir have been fitted.**

1. Connect female terminals of the loom on to the reservoirs.

2. Remove the 2 pin plug from the loom and insert through the grommet of the reservoir mounting plate.

3. Fit 2 pin plug back on to the loom and connect to the main loom. 2 x brown and white wires.

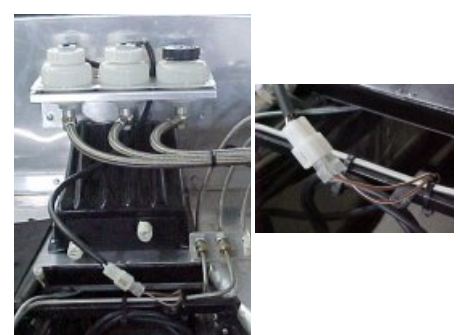

## 6:4 WIRING AND SWITCHES - K3601125AB

Components in this assembly		Qty	Part Number
i	Relay flasher hazard	2	B5451111AA
ii	Relay ign / windscreen	3	B5451113AA
iii	Relay dip	1	B5451114AA
iv	Switch headlight	1	B5451127AA
v	Fuse box	2	B5451130AA
vi	Switch wiper	1	B5451132AA
vii	Cable tie 8"	20	B5451180AA
viii	Switch hazard	1	B5451220AA
ix	Fuse 15AMP	8	B5451257AA
x	Fuse 25AMP	4	B5451258AA
xi	Sleeving 4mm PVC	0.70m	B5451315AA
xii	Wire 2mm red	0.75m	B5451442AA
xiii	Wire for hazard switch	1	M3501018AA



**All components in this section are to be fitted to the vehicle before the scuttle is finally fitted.**



**Remove the connector relay from the mounting plate.**

### Relay hazard flasher fitting procedure

The relay from the third and fifth connector has three pins and is used for two purposes:

- i) Hazard wiring circuit
- ii) Indicator wiring circuit

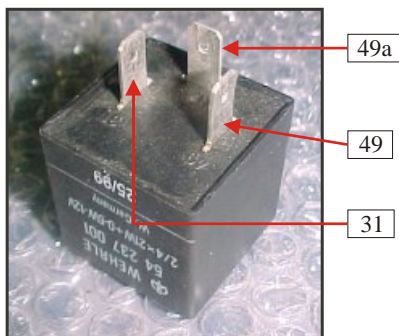

### HAZARD WIRING CIRCUIT:

1. The wires need to fit into the third connector.

49 - Red/White wire (from fusebox)  
 49a - Grey wire (from the hazard switch)  
 31 - Brown wire (ground)

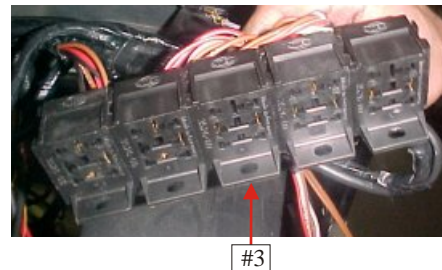

2. Insert wiring into the connector matching the colour of the wire with the correct pin on the relay.



### INDICATOR WIRING CIRCUIT:

1. The wires need to fit into the fifth connector.

49 - White/Green (from the hazard switch)  
 49a - Green/White (from indicator switch)  
 31 - Brown (ground)

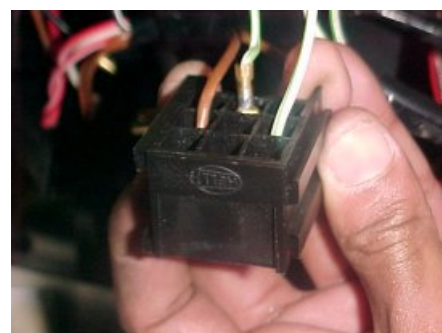
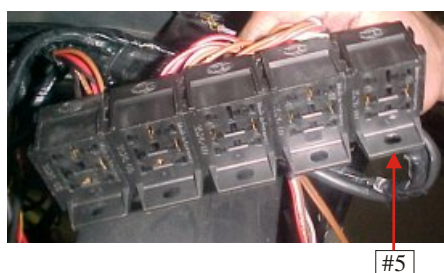

## Relay ignition / windscreen fitting procedure

The relay from the first, second and fourth connector has five connecting pins and is used for three purposes:

- i) Ignition wiring circuit
- ii) Headlamp wiring circuit
- iii) Heated windscreen wiring circuit

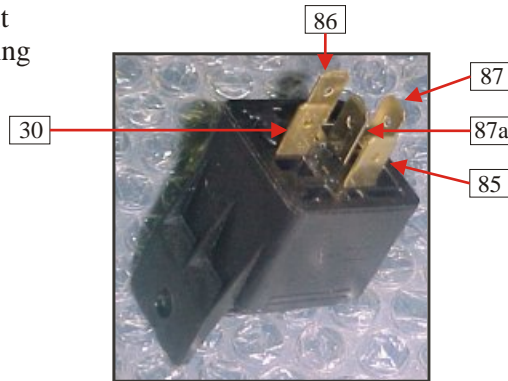

### IGNITION WIRING CIRCUIT:

1. The wires need to fit into the first connector.

2. Insert wiring into the connector matching the colour of the wire with the correct pin on the relay.



30 - 2mm Black wire

85 - Brown wire

86 - 1mm Black wire

87 - Double wire Red/Black and Red/White wire

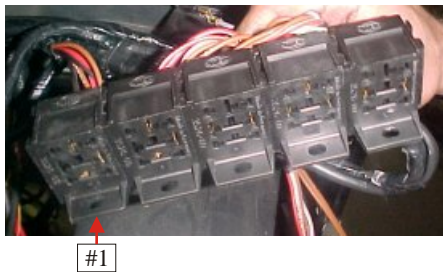

### HEADLIGHT WIRING CIRCUIT:

1. The wires need to fit into the second connector.

2. Insert wiring into the connector matching the colour of the wire with the correct pin on the relay.



30 - Red/Black wire

85 - Brown wire

86 - Black/White wire

87 - White wire

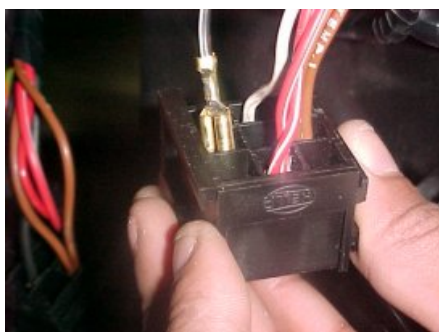
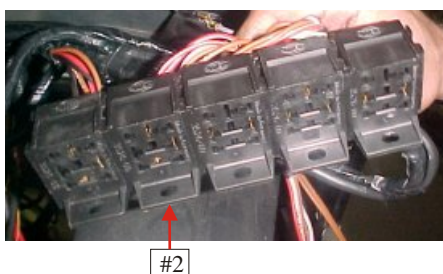

## HEATED WINDSCREEN WIRING CIRCUIT:

1. The wires need to fit into the fourth connector.



#4

2. Insert wiring into the connector matching the colour of the wire with the correct pin on the relay.

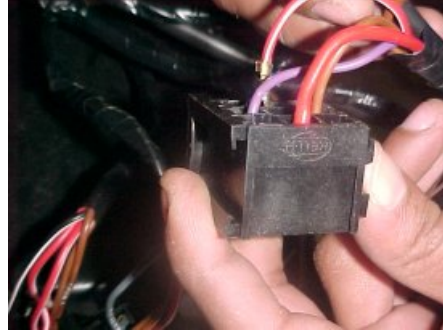

30 - Red wire

85 - Brown wire

86 - Purple wire

87 - Red / White wire

3. Cable tie the wire neatly above the relay connector.

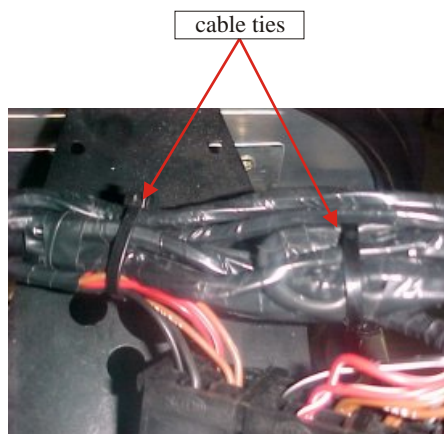

cable ties

4. Refit the connector to the wiring bracket.

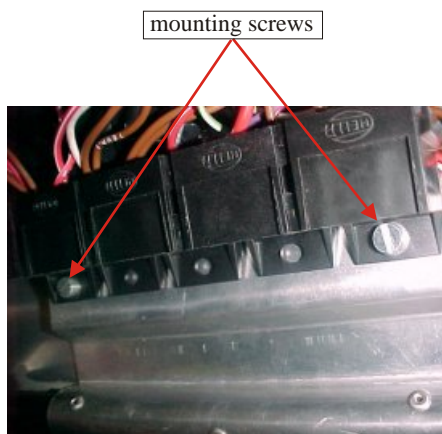

mounting screws

5. Fit the relays to their correct connectors.

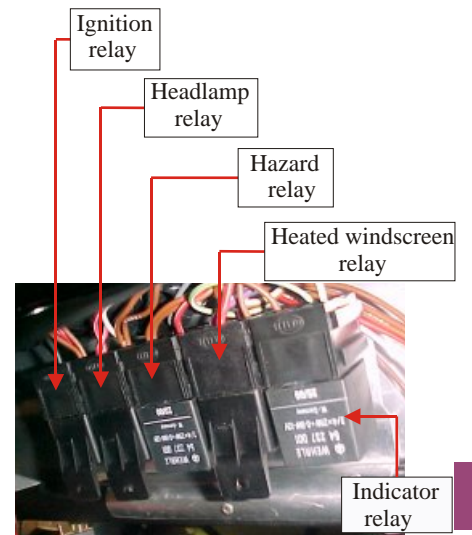

Ignition relay

Headlamp relay

Hazard relay

Heated windscreen relay

Indicator relay

## Relay dip fitting procedure

1. The relay five connector pins.

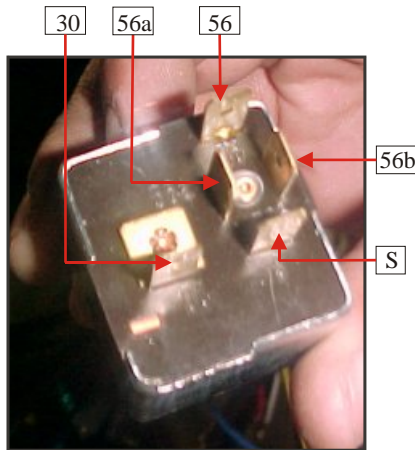

**30 - Red wire**

**S - Blue wire**

**56 - White wire**

**56a - 2mm Yellow wire**

**56b - 2mm White wire**

2. Cable tie the relay to the wiring harness between 8 pin connectors and wiper motor.

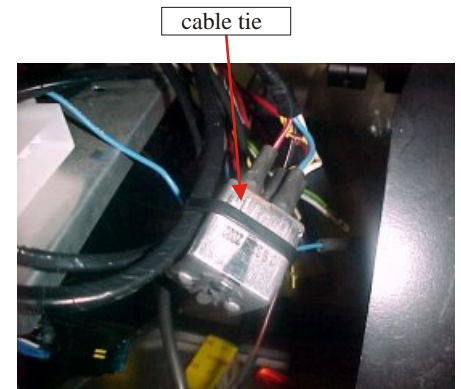

## Fusebox fitting procedure

1. Fit fuses to the fusebox as illustrated below.

2. Connect wiring to fusebox using the diagram as a guide.

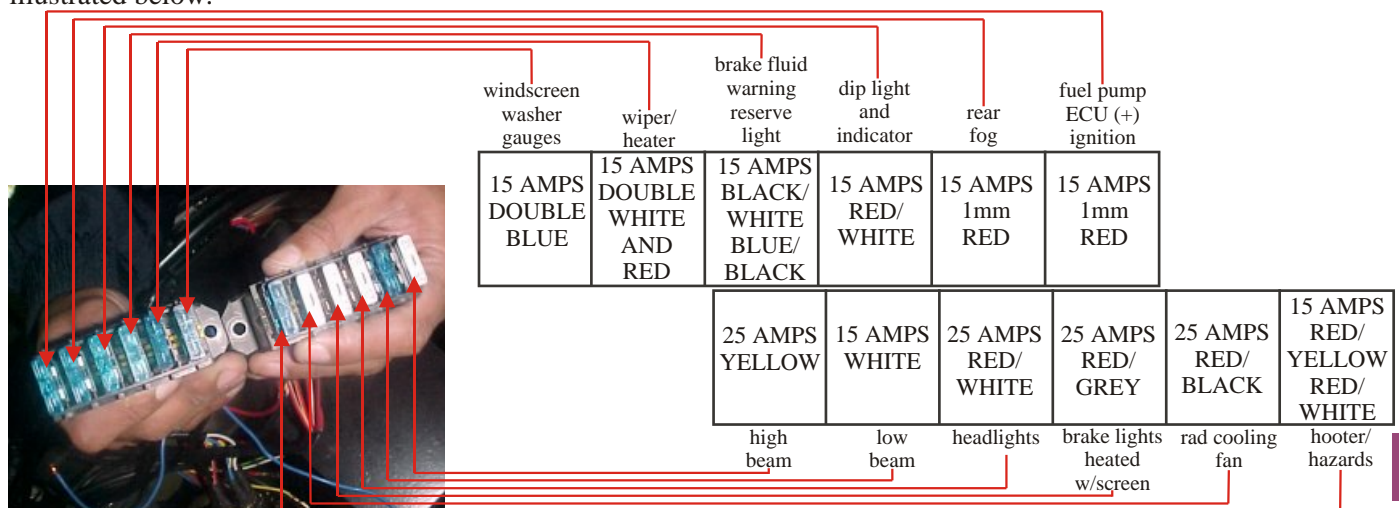

3. Fit the fusebox to the mounting plate using four 5mm screws, eight 5mm washers and four 5mm Nyloc nuts.

4. Cable tie the wires neatly.

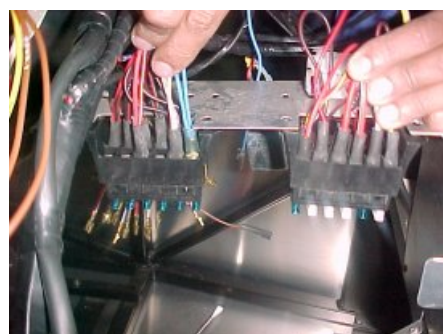

## Switch fitting procedure

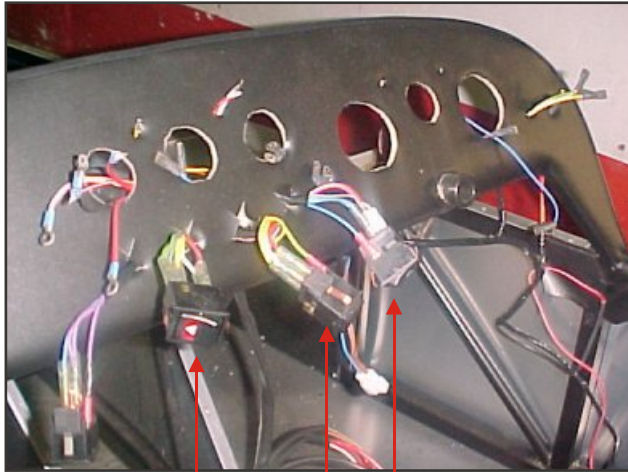

Headlight switch



Wiper motor switch



Hazard switch

Fit wires to switches as illustrated below.

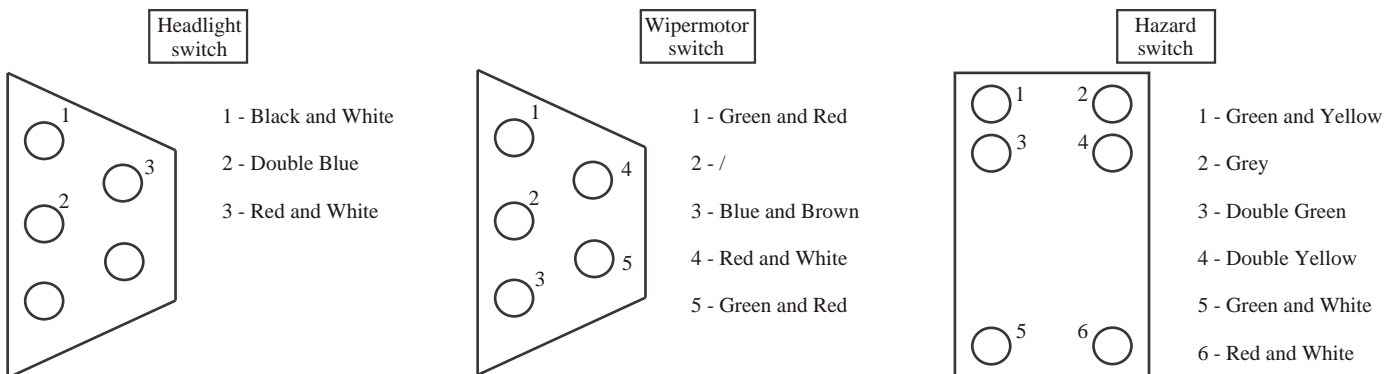

Once correctly wired, insert switches into the dashboard, avoid damaging the vinyl covering the dashboard.



## 6:5 INDICATOR PILOT LIGHT - K3601124AA

Components in this assembly		Qty	Part Number
i	Washer 3mm flat	8	B5358005AA
ii	Screw M3 x 20	4	B5358105AA
iii	Nut M3 E/Gal	4	B5358106AA
iv	Lamps indicator	1	B5451327AA

### Indicator pilot light fitting procedure

1. Stick masking tape on the outside edge of both cycle fenders directly above the centre of the wheel hub.

2. With a plumblines and pen, mark the masking tape directly over the centre of the wheel hub.

3. Remove the lens from both indicator lights.

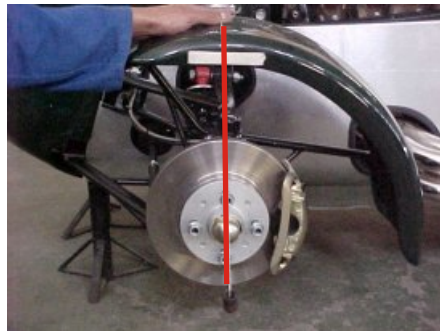

4. Place the indicator fitting so that the line drawn on the masking tape is in the middle. Mark the two mounting holes and a hole in the middle of the indicator fitting for the loom to pass through.

5. Drill two 3mm holes for mounting the indicator to the fender and one for the 5mm hole for the loom to pass through.

6. Feed the loom through and strip away excess out loom tubing to expose two black wires. Allow only 30mm of black wire to protrude the fender. Cut away any excess. Strip about 5mm of insulation from the ends of the wire.

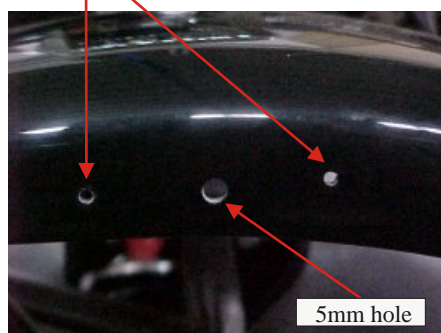

## Indicator pilot light fitting procedure continue

---

7. Secure one wire to the left clamp terminal.



8. Solder remaining wire to the right terminal.



9. Fit the light bulb and mount the light to the fender with the M3 x 20 screws (ii), M3 E/Gal nuts (iii) and 3mm flat washers (i) with a washer on both sides of the unit.



**Do not over tighten as this will crack the lens of the indicator lamp.**

10. Fit 'P' clip to the loom and attach the 'P' clip to the front mounting screw. This prevents the loom from coming into contact with the tyre.

'P' clip

