

GROUP TWO

STEERING AND PEDALS - R.H.D

Assemblies included In this group: -

2:1	K3601043AD	STEERING COLUMN
2:2	K3601042AB	STEERING RACK
2:3	K3601045PA	PEDAL BOX

Tools required for assembly of this group: - Qty

2mm Allen Key	1
13mm Spanner	1
6mm Allen Key	1
Torque Wrench with range 8 - 50 Nm	1
13mm Socket to fit torque wrench	1
Vernier Calliper or Measuring Tape (mm)	1
3mm Allen Key	1
Craft Knife	1

K3601043AD STEERING COLUMN

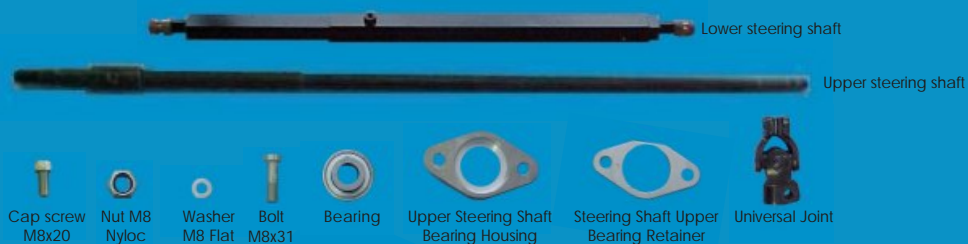

K3601042AB STEERING RACK



K3601045PA PEDAL BOX

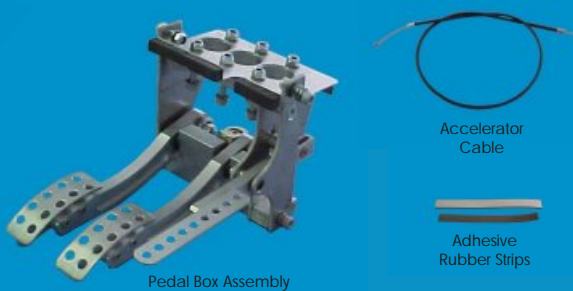

Components in this assembly		Qty	Part Number
i	Bolt M8x31	4	M3101353AA
ii	Upper steering shaft	1	M3151071AD
iii	Steering shaft upper bearing retainer	1	M3871040AA
iv	Cap screw M8x20	2	B5358016AA
v	Washer 08mm flat	2	B5358088AA
vi	Nut M8 Nyloc	6	B5358092AA
vii	Bearing	1	B5451711AA
viii	Lower steering shaft	1	M3151079AA
ix	Upper steering shaft bearing housing	1	M3101381AA
x	Universal joint	2	M3101459AA

Procedure

1. Offer the upper steering shaft to the chassis by passing the small end (short spline) through the bearing retaining bracket attached to the chassis member at the front of the pedal / foot box.



2. Place the bearing retainer plate over the top end of the shaft and slide it down to meet the bracket attached to the chassis member.



3. Slide the top end of the steering shaft back up through the steering lock housing and top nylon bush.



4. Fit the upper shaft bearing into the aluminium bearing housing as illustrated.

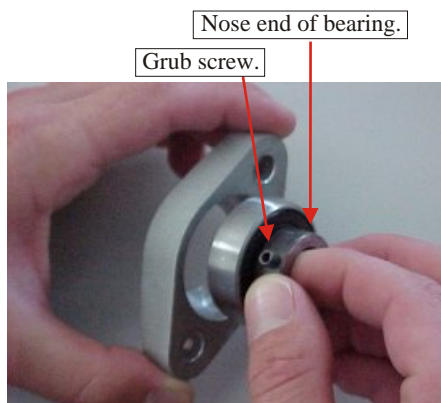

5. Place the bearing in its housing over the end of the shaft protruding through the front of the pedal / foot box with the grub screw / nose end of the bearing facing the dashboard.



6. Use two M8x20 cap screws, flat washers and Nyloc nuts to bolt the bearing housing, mounting bracket and bearing retainer plate together. **Torque to 11 (eleven) Nm.**



Steering Column Procedure cont.

7. Position the upper shaft to protrude 51mm from the thrust face of the nylon bush (supplied in Group 1) in the steering lock housing.

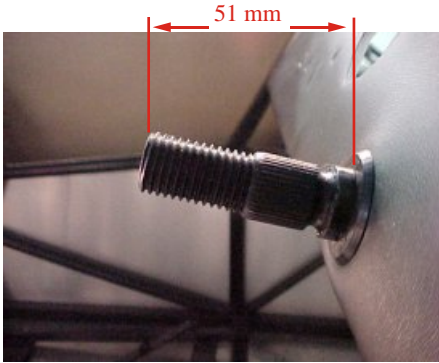

8. Lock the shaft in position by tightening the two grub screws on the nose of the upper shaft bearing.



The shaft splines have a groove machined in their mid section to allow the M8 bolt passing through the universal joint shoulder to locate the shafts in position.

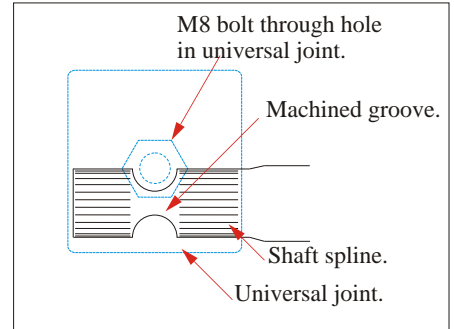

9. Using a M8x31 bolt and Nyloc nut fit one of the universal joints to the spline on the end of the upper steering shaft protruding through the foot box. (For the purpose of installation, this shall be called the 1st universal joint.)



The lower steering shaft has a top and bottom spline illustrated below.

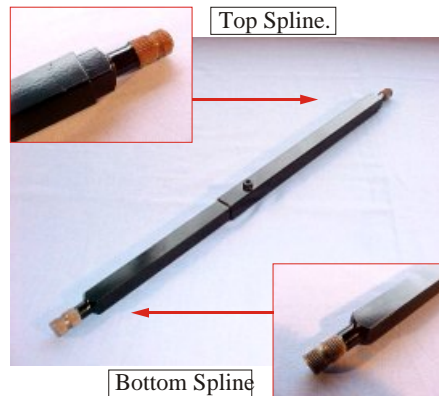

10. Fit the second universal joint to the bottom spline of the lower steering shaft using a M8x31 bolt and Nyloc nut. (For the purpose of installation, this shall be called the 2nd universal joint.)



11. Using another M8x31 bolt and Nyloc nut, fit the top spline of the lower steering shaft to the open end of the 1st universal joint.



Universal joints attached to the same shaft must be aligned so that the connecting ends form a mirror image of each other as pictured below.

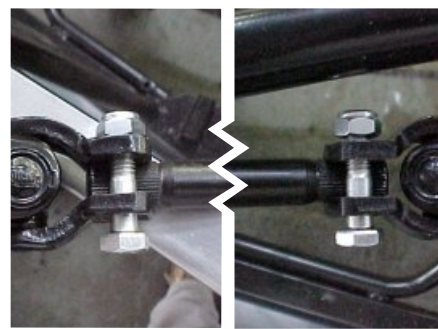

Torque all three universal joint bolts to 11 (eleven) NM

Components in this assembly		Qty	Part Number
i	Cap screw M8 x 100 S/S	4	B5358052AA
ii	Washer 8mm flat	4	B5358088AA
iii	Nut M8 Nyloc	4	B5358092AA
iv	Sleeve rack mounting	2	M3851176AA
v	Steering rack mounting	2	M3101021AB
vi	Spacer rack mounting	2	M3251006AA
vii	Steering rack	1	M3101017AB

Procedure

1. Feed the steering rack through the cut-outs in the front of the chassis as illustrated below.

2. Loosen the grub screw on the centre of the lower steering shaft to allow the two halves to move freely.



3. Insert the rack pinion into the 2nd universal joint and secure using a M8x31 bolt and Nyloc nut.

4. Place the lower halves of the aluminium steering rack mountings (The half without the Embossed BIRKIN logo) under the steering rack and onto the rack platform in the positions illustrated below



The rack mountings come in matched pairs indicated by the numbering on their sides.



Steering Rack Procedure Continued.

5. Fit the two halves of the rack mounting sleeve in the position illustrated below.

Two halves of the Rack Sleeve

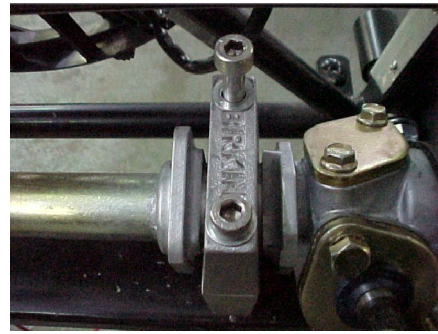
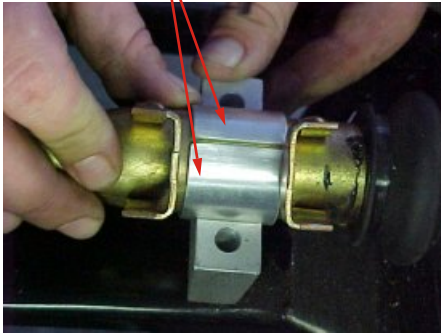

7. Ensure the rack pinion and lower steering shaft form a straight line when viewed from the side. Then torque the rack mounting cap screws to 28 (twenty eight) Nm.



8. Torque the bolt fitted to the 2nd universal joint in step 3 of this procedure to 11 (eleven) Nm. Tighten the grub screw on the lower steering column.



The installation of the steering column and rack is now complete. The bolts, cap screws and grub screws will not need to be loosened at any further stage however, should it be necessary to loosen any of the above, it is important to note the following:

1. It is advisable with any Nyloc nut, once it has been torqued and then loosened, it should not be reused.
 2. When re-tightening, make sure the respective bolt and nut is re-torqued to its original setting.
-

Components in this assembly		Qty	Part Number
i	Rubber strips 300mm	2	B5451232AA
ii	Accelerator cable	1	B5451770AA
iii	Pedal box assembly part of which includes:	1	M3551041PA
	Cap screw M8x25	3	B5358185AA
	Cap screw M8x50	1	B5358237AA
	Washer 8mm mild steel	8	B5358088AA
	Washer 8mm stainless steel	6	B5358208AA
	M8 Nyloc nut.	2	B5358092AA

Procedure



To vary the driving position, the pedal box may be installed in one of three positions according to the length of the driver's legs. The three positions are: ① - Forward, ② - Centre and ③ - Rear. These positions may be adjusted after installation which is explained at the end of this section.

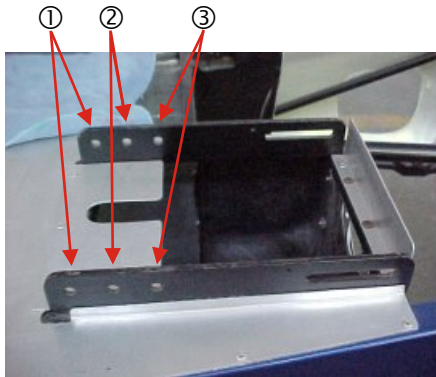

1. Remove the backing on the two rubber strips to reveal the adhesive and apply to the pedal box frame as illustrated below.



2. Using a craft knife, carefully cut away the rubber from the slotted cut outs on the pedal box runners.



3. Remove the three M8x25 and one M8x50 cap screws, washers and Nyloc nuts from the rear and front mounting points on the pedal box assembly.

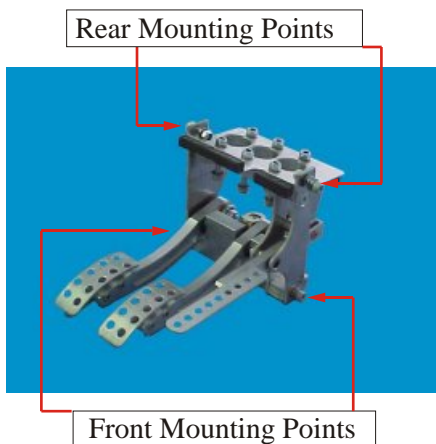

Take note of how the M8x50 cap screw is placed through the accelerator bracket. It will need to be replaced in this position in stage 5. of this procedure.



Take note of the two different types of washers, There are eight, 8mm mild steel washers which are thinner than the six, 8mm stainless steel washers. It is important to keep the two types separate until step 5. of this procedure.

4. Position the pedal box between the pedal box runners according to the desired driver position.



As the seats need to be fitted to ascertain the correct driving position, an estimate should be made at this stage



Procedure

5. Replace the three M8x25 and one M8x50 cap screws, washers and Nyloc nuts in their original positions.



Make sure the M8x50 cap screw is replaced through the accelerator bracket as illustrated below.



Although the accelerator cable is supplied with this Group, it is not installed until completion of the engine installation.



As illustrated below, two 8mm mild steel washers must be placed in the X and Y positions between the pedal box and the runners, then one 8mm stainless steel washer in the W and Z positions. The cap screws used on the front mounting points of the pedal box do not have a washer in the W position.

Accelerator Bracket

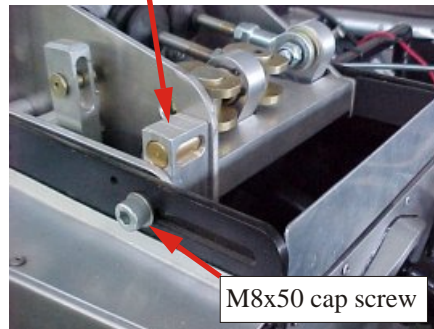

Master Cylinders are supplied in Group 10 where the installation is described.

Position of Pedal box.

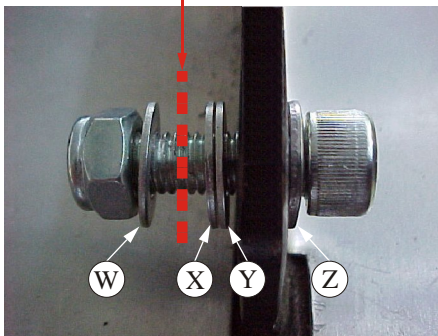

To protect the Nyloc nuts, the cap screws must not be tightened until the final pedal box position has been ascertained. Final tightening is described in the procedure below.

Final Pedal Box Position Adjustment Procedure

1. Remove only the M8x25 cap screws, washers and Nyloc nuts from the rear pedal box mounting points. Refer to step 3. of the above procedure to see the different mounting points.



Take care not to lose the washers concealed between the pedal box and the runners.

2. Loosen the M8x25 and M8x50 cap screws in the front mounting points until the pedal box is able to slide freely between the pedal box runners to the selected position. Refer to beginning of the above procedure for the three possible pedal box positions.



Do not completely remove the cap screws on the front mounting points when adjusting an installed pedal box.



The positions of the two different types of washers for the rear mounting points are important. Refer to steps 3 and 5. of the above procedure for details on their type and positioning.



Tighten the four cap screws to 11 (eleven) Nm.